

WR90 SEALED SER.

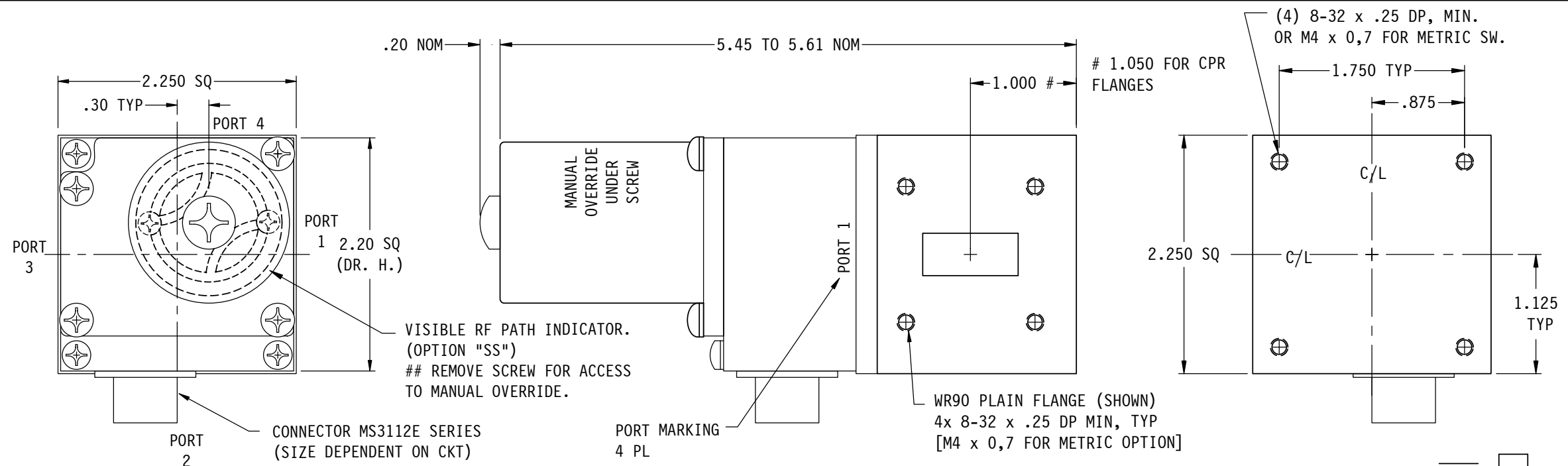

SPECIFICATIONS:
 FREQ RANGE — 8.20 TO 12.40 GHz
 VSWR — 1.05 : 1 MAX
 INSERTION LOSS — 0.05 db MAX
 ISOLATION — 60 db MIN
 SWITCHING TIME — 50 mSEC, TYP
 PRESSURE — TO 30 PSIG (R-F HEAD)
 FINISH — IRIDITE ON FLANGES, SATIN BLACK FINISH ON REST OF BODY.

NOTES:
 1. ** MANUAL SWITCH DOES NOT INCLUDE RECEPTACLE.
 2. BLUE BOXES ARE REQUIRED FIELDS.
 3. !! IF OPTION IS NOT REQUIRED, LEAVE (GOLD BOX) BLANK

VOLTAGE	AMPS	CODE
+22 TO +32	0.9	A
-22 TO -32	0.9	B
+10 TO +14	1.5	C
-10 TO -14	1.5	D
+44 TO +54	0.5	E
-44 TO -54	0.5	F
117VAC	0.5	H
235VAC	0.5	K
MANUAL **		M

PART NO. SELECTION

CODE	FLANGE
P	PLAIN
C	CHOKE
O	O-RING
F	CPRF
G	CPRG

CODE	!! OPTION
M	METRIC THREAD

TOP EXTERIOR SCREW CAN BE REMOVED ALLOWING ACCESS TO MANUAL OVERRIDE. No. 1 PHILLIPS SCREWDRIVER REQUIRED.

CODE	ENVIRONMENTAL
S	SEALED
SS	## SEALED WITH REMOVABLE SCREW

!! OPTION	CODE
SPDT	1

X						
PART NO. SERIES	X	FAILSAFE	F	!! OPTION	CODE	!! ELECTRICAL CIRCUIT (IF OTHER THAN STD.) SEE SCHEMATIC PAGE

PART NO. EX.: XAPS2
 WR90 WG SWITCH, +28VDC, PLAIN FLANGE, SEALED, CKT #2

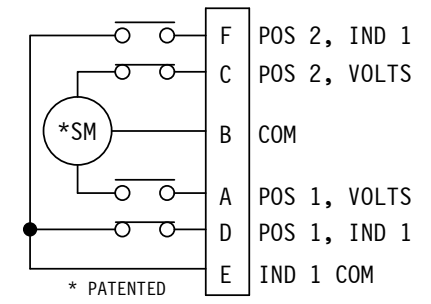

STD. ELECT. CKT. Shown in Pos. 1 ONE FORM C

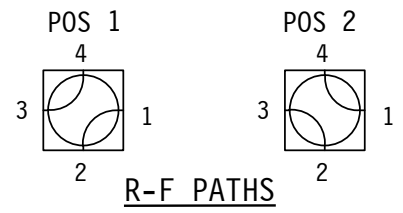

TOLERANCES: DECIMALS 2 PLACES: +/- .03 3 PLACES: +/- .010 FRACTIONS: +/- 1/32 ANGLES: +/- 1/2 deg.	DRAWN A.C. 12/9/03
	CHECKED
	APVD T.N. 12/9/03
	APVD

SECTOR MICROWAVE IND., INC.			
WR90 W/G SWITCH SEALED SERIES			
SIZE L	CAGE CODE 53263	WR90 SEALED SER.	A
SCALE: NONE	UNIT WT.	SHEET 1 OF 1	REV.

ZONE	LTR	DESCRIPTION	APV	DATE
	A	RELEASED.	TN	12/9/03
REVISIONS				

WEB SITE: www.sectormicrowave.com