

MANUAL OVERRIDE & R-F PATH INDICATOR

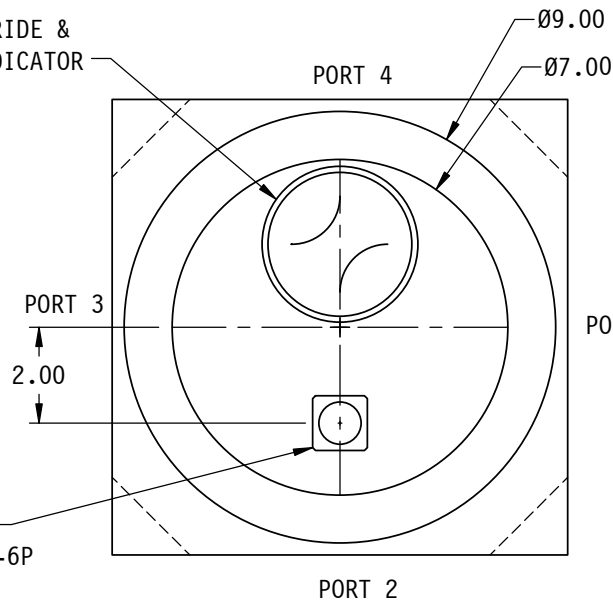

CONNECTOR
MS3102A14S-6P
(STD CKT)

PORT 1

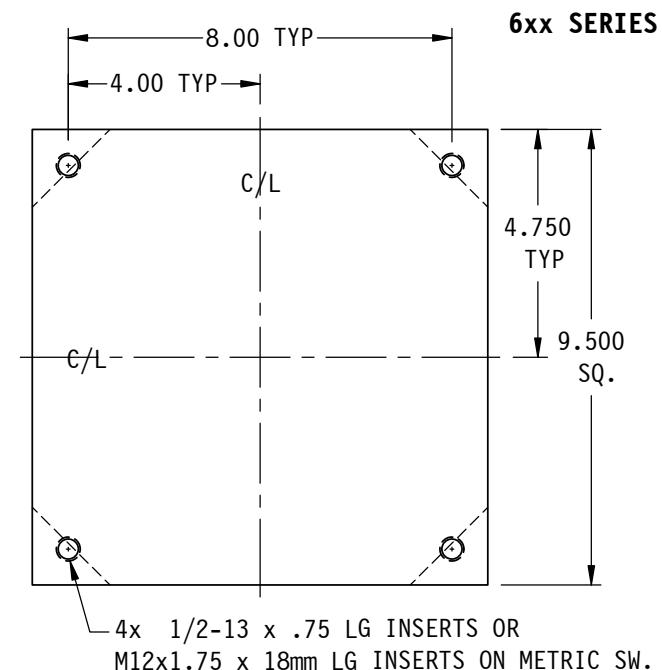
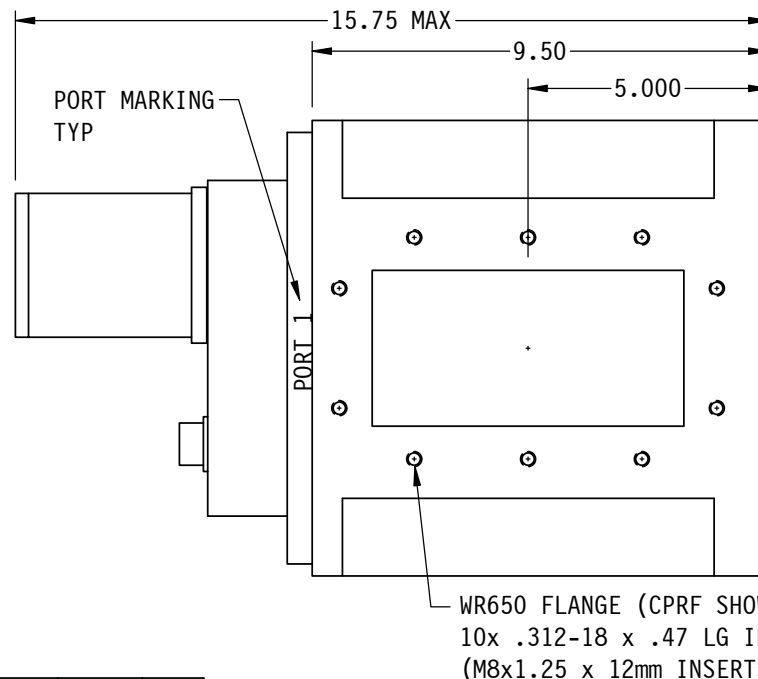

SPECIFICATIONS:

- FREQ RANGE ——— 1.12 TO 1.70 GHz
- VSWR ——— 1.05 : 1 MAX
- INSERTION LOSS ——— 0.01 db MAX
- ISOLATION ——— 80 db MIN
- SWITCHING TIME ——— 1.0 SEC NOM
- PRESSURE ——— TO 30 PSIG (R-F HEAD)
- MATERIAL/FINISH ——— ALUM ALY / SATIN BLACK ENAMEL, IRIDITE ON FLANGE FACES.

VOLTAGE	AMPS	CODE
+22 TO +32	5	A
-22 TO -32	5	B
+10 TO +14	-	C
-10 TO -14	-	D
+44 TO +54	-	E
-44 TO -54	-	F
117VAC	2	H
235VAC	-	K
MANUAL **	-	M

PART NUMBER SELECTION

CODE	FLANGE
F	CPRF
G	CPRG

CODE	!! OPTION
M	METRIC THREAD

!! OPTION	CODE
SPDT	1

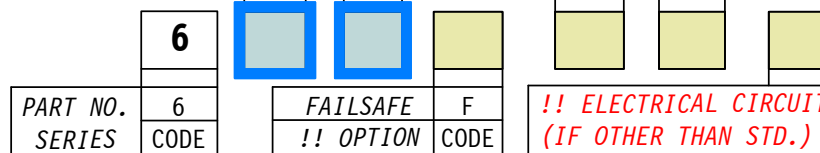

PART NO. EX.: 6AFM6A
WR650 WG SWITCH, +28VDC, CPRF
FLANGE, METRIC THDS., ELECT CKT #6A.

!! ELECTRICAL CIRCUIT (IF OTHER THAN STD.) SEE SCHEMATIC PAGE.

WEB SITE: www.sectormicrowave.com

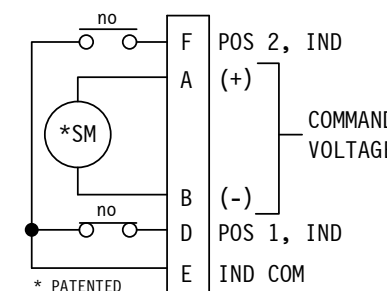

STD. FAILSAFE ELECT CKT. Shown in De-energized Pos. ONE FORM C

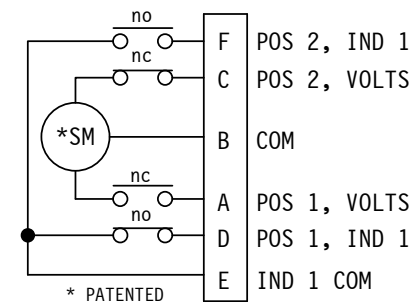

STD. ELECTRICAL CKT. Shown in Position 1 ONE FORM C

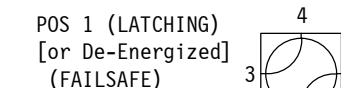
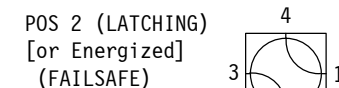

R-F PATHS

NOTES:

1. ** MANUAL SWITCH DOES NOT INCLUDE RECEPTACLE.
2. BLUE BOXES ARE REQUIRED FIELDS.
3. !! IF OPTION IS NOT REQUIRED, LEAVE (GOLD BOX) BLANK

ZONE	LTR	DESCRIPTION	APV	DATE
	A	RELEASED.	AC	10/8/06
REVISIONS				

TOLERANCES:	DRAWN	A.C.	10/8/06
DECIMALS	CHECKED		
2 PLACES: +/- .03	APVD	R.R.	10/8/06
3 PLACES: +/- .010	APVD		
FRACTIONS: +/- 1/64			
ANGLES: +/- 1/2 deg.			

SECTOR MICROWAVE IND., INC.			
WR650 WAVEGUIDE SWITCH, MINI-SERIES			
SIZE	L	MFG CODE	53263
		6xx SERIES	A
SCALE: NONE	UNIT WT.	SHEET 1 OF 1	REV.