

WR10 SERIES

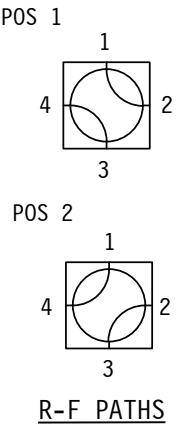
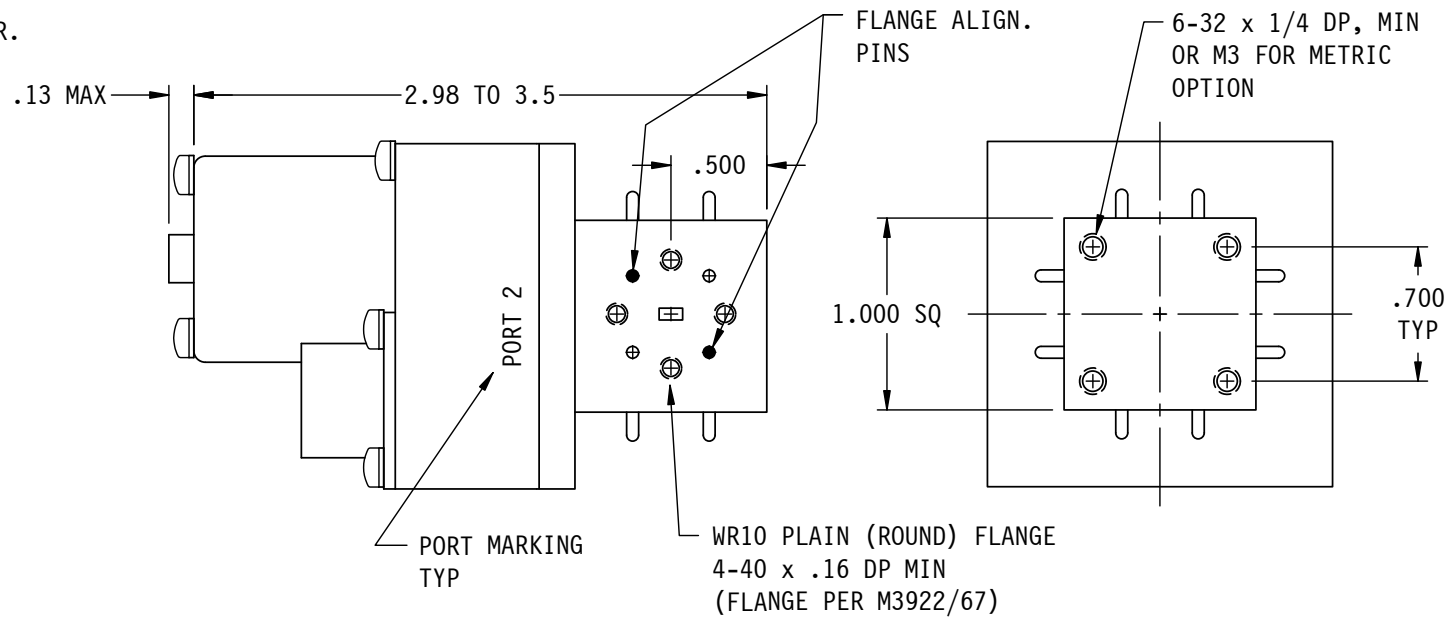
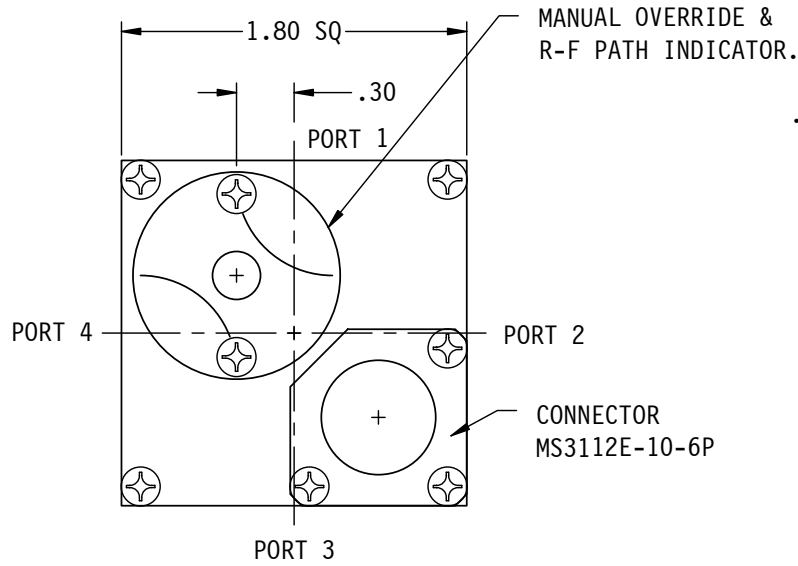

SPECIFICATIONS;
 FREQ RANGE (GHz) — 75.0 - 110.0
 VSWR — 1.20 : 1 MAX
 INSERTION LOSS — 0.40 db, MAX
 ISOLATION — 50 db, MIN
 SWITCHING TIME — 50 mSec, TYP
 PRESSURE — TO 30 PSIG (R-F HEAD)
 FINISH — IRIDITE ON FLANGES, SATIN BLACK ENAMEL ON BODY.

- NOTES:**
 1. ** MANUAL SWITCH DOES NOT INCLUDE RECEPTACLE.
 2. BLUE BOXES ARE REQUIRED FIELDS.
 3. !! IF OPTION IS NOT REQUIRED, LEAVE (GOLD BOX) BLANK

VOLTAGE	AMPS	CODE
+22 TO +32	0.9	A
-22 TO -32	0.9	B
+10 TO +14	1.5	C
-10 TO -14	1.5	D
+44 TO +54	0.5	E
-44 TO -54	0.5	F
117VAC	0.5	H
MANUAL **		M

PART NO. SELECTION

!! OPTION	CODE
METRIC THREAD	M

CODE	FLANGE
P	PLAIN (ROUND)

10	P
SPDT	1
!! OPTION	CODE

PART NO. EX.: 10APM

WR10 LATCHING WG SWITCH, +28VDC, PLAIN ROUND FLANGE, METRIC MTG HOLES ON BOTTOM

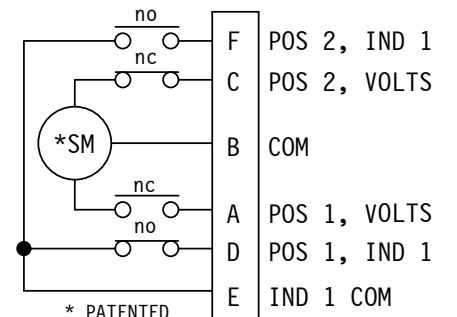

STD. ELECTRICAL CKT.
 Shown in Position 1
 ONE FORM C

WEB SITE: www.sectormicrowave.com

ZONE	LTR	DESCRIPTION	APV	DATE
	B	DELETED FAILSAFE OPTION	TN	2/12/08
	A	ADDED NOTE 1 & CALLOUTS. CLARIFIED FLANGE INFO.	AC	12/21/98
REVISIONS				

TOLERANCES: DECIMALS 2 PLACES: +/- .03 3 PLACES: +/- .010 FRACTIONS: +/- 1/64 ANGLES: +/- 1/2 deg.		DRAWN	A.C.	10/17/97	SECTOR MICROWAVE IND., INC.
		CHECKED			
		APVD	J.P.	10/17/97	
		APVD			
		WR10 WG SW. : LIGHTWT. SER.			WR10 SERIES
SIZE	L	CAGE CODE	53263		
		SCALE: 1/1	UNIT WT.	SHEET 1 OF 1	B REV.